



# HEAVY DUTY SERIES



**BLEUTEC**  
**WHEELS & CASTERS**

The art of improving, a never ending story

[www.bleutec.com](http://www.bleutec.com)

## ALTH SERIES

Heavy duty wheels with Blicke Extrathane® polyurethane tread  
Aluminium wheel centre  
1210 to 1760 lbs



### WHEEL DESCRIPTION:

Tread made of Blicke Extrathane® polyurethane, firmly bonded, light brown colour, non-marking, 92° shore A, elastic, abrasion-resistant, high cut and tear propagation resistance, non-staining, floor-saving, low-noise operation, low rolling resistance, very good chemical connection with the wheel centre. Wheel centres made of aluminium die-cast, corrosion-resistant, ball bearing, aluminium colour.

### RIGS: LO/BO SERIES

**Heavy welded steel construction**, swivel bracket with double ball bearing in the swivel head, additionally reinforced by the integration of four specially shaped and hardened bearing seats, labyrinth swivel head sealing with grease nipple, welded very strong, bolted and secured central kingpin, bolted wheel axle, zinc-plated.

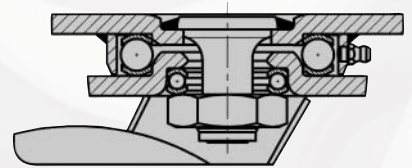

### EXTRATHANE® POLYURETHANE – PRECISION BALL BEARING

6"	8 1/16"	2"	5 1/2" x 4 3/8"	4 1/8" x 3 1/8"	lbs	bearing type	swivel	rigid	"stop-top" brake
8"	9 5/8"	2"	5 1/2" x 4 3/8"	4 1/8" x 3 1/8"	1210	Ball bearing	LO-ALTH 160K	BO-ALTH 160K	LO-ALTH 160K-ST
					1760	Ball bearing	LO-ALTH 200K	BO-ALTH 200K	LO-ALTH 200K-ST

## GTH SERIES

Heavy duty wheels with Blicke Extrathane® polyurethane tread  
Cast iron wheel centre  
1650 to 2640 lbs



### WHEEL DESCRIPTION:

Made of Blicke Extrathane® polyurethane, firmly bonded, light brown colour, non-marking, 92° shore A, elastic, abrasion-resistant, high cut and tear propagation resistance, non-staining, floor-saving, low noise operation, low rolling resistance, very good chemical connection with the wheel centre.

### RIGS: LO/BO SERIES

**Heavy welded steel construction**, swivel bracket with double ball bearing in the swivel head, additionally reinforced by the integration of four specially shaped and hardened bearing seats, labyrinth swivel head sealing with grease nipple, welded very strong, bolted and secured central kingpin, bolted wheel axle, zinc-plated.

### EXTRATHANE® POLYURETHANE – PRECISION BALL BEARING

6"	8 1/16"	2"	5 1/2" x 4 3/8"	4 1/8" x 3 1/8"	lbs	bearing type	swivel	rigid	"stop-top" brake
8"	9 5/8"	2"	5 1/2" x 4 3/8"	4 1/8" x 3 1/8"	1650	Ball bearing	LO-GTH 160K	BO-GTH 160K	LO-GTH 160K-ST
					2200	Ball bearing	LO-GTH 200K	BO-GTH 200K	LO-GTH 200K-ST
10"	11 5/8"	2 3/8"	5 1/2" x 4 3/8"	4 1/8" x 3 1/8"	2640	Ball bearing	LO-GTH 250K	BO-GTH 250K	LO-GTH 250K-ST

## ALST SERIES

Heavy duty wheels with **Blickle Softhane®** polyurethane tread  
Aluminium wheel centre  
1210 to 1760 lbs

### WHEEL DESCRIPTION:

Made of **Blickle Softhane®** polyurethane, firmly bonded, green colour, non-marking, 75° shore A, **very high operational comfort because of particularly thick elastic tread**, abrasion-resistant, high cut and tear propagation resistance, non-staining, floor saving, low noise operation, low rolling resistance, very good chemical connection with the wheel centre.







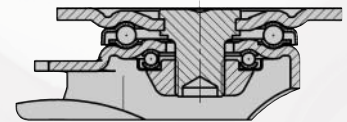

### RIGS: LH/BH SERIES

**Pressed steel**, swivel bracket with double ball bearing in the reinforced swivel head, dynamically pressed in accordance with special Blickle procedure resulting in an extremely low swivel head play and long service life, strong central kingpin, swivel head sealing, bolted wheel axle, zinc-plated.



### SOFTHANE® POLYURETHANE – PRECISION BALL BEARING

										
						lbs	bearing type	swivel	rigid	"stop-fix" brake
6"	8"	2"	5 1/2" x 4 3/8"	4 1/8" x 3 1/8"		1210	Ball bearing	LH-ALST 160K	BH-ALST 160K	LH-ALST 160K-FI
8"	9 5/8"	2"	5 1/2" x 4 3/8"	4 1/8" x 3 1/8"		1540	Ball bearing	LH-ALST 200K	BH-ALST 200K	LH-ALST 200K-FI
10"	11 5/8"	2"	5 1/2" x 4 3/8"	4 1/8" x 3 1/8"		1760	Ball bearing	LH-ALST 250K	BH-ALST 250K	LH-ALST 250K-ST*

\* "stop-top" braking system

## ALST SERIES

Heavy duty wheels with **Blickle Softhane®** polyurethane tread  
Aluminium wheel centre  
1210 to 1760 lbs

### WHEEL DESCRIPTION:





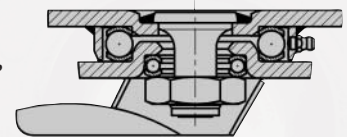

Made of **Blickle Softhane®** polyurethane, firmly bonded, green colour, non-marking, 75° shore A, **very high operational comfort because of particularly thick elastic tread**, abrasion-resistant, high cut and tear propagation resistance, non-staining, floor saving, low noise operation, low rolling resistance, very good chemical connection with the wheel centre.

### RIGS: LO/BO SERIES

**Heavy welded steel construction**, swivel bracket with double ball bearing in the swivel head, **additionally reinforced by the integration of four specially shaped and hardened bearing seats**, labyrinth swivel head sealing with grease nipple, welded very strong, bolted and secured central kingpin, bolted wheel axle, zinc-plated.



### SOFTHANE® POLYURETHANE – PRECISION BALL BEARING

										
						lbs	bearing type	swivel	rigid	"stop-top" brake
6"	8 1/8"	2"	5 1/2" x 4 3/8"	4 1/8" x 3 1/8"		1210	Ball bearing	LO-ALST 160K	BO-ALST 160K	LO-ALST 160K-ST
8"	9 5/8"	2"	5 1/2" x 4 3/8"	4 1/8" x 3 1/8"		1540	Ball bearing	LO-ALST 200K	BO-ALST 200K	LO-ALST 200K-ST
10"	11 5/8"	2"	5 1/2" x 4 3/8"	4 1/8" x 3 1/8"		1760	Ball bearing	LO-ALST 250K	BO-ALST 250K	LO-ALST 250K-ST

## SE SERIES

Heavy duty wheels with elastic solid rubber tread  
Welded steel wheel centre  
880 to 1100 lbs



### WHEEL DESCRIPTION:

Elastic solid rubber, smooth rolling quality, black, 65° shore A, vulcanised, non-detachable connection.

### RIGS: LH/BH SERIES

**Pressed steel**, swivel bracket with heavy fork and top plate, very strong bolted and secured central kingpin, double ball bearing in the swivel head, additionally reinforced by the integration of four specially shaped and hardened bearing seats resulting in a very high resistance to shock and impact loads, bolted wheel axle, zinc plated.

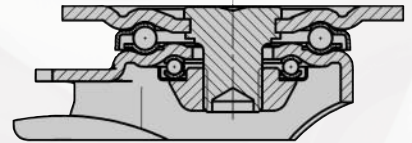

### ELASTIC SOLID RUBBER – PRECISION BALL BEARING

6"	8"	2"	5 1/2" x 4 3/8"	4 1/8" x 3 1/8"	lbs	bearing type	swivel	rigid	"stop-fix" brake
6"	8"	2"	5 1/2" x 4 3/8"	4 1/8" x 3 1/8"	880	Ball bearing	LH-SE 160K	BH-SE 160K	LH-SE 160K-FI
8"	9 5/8"	2"	5 1/2" x 4 3/8"	4 1/8" x 3 1/8"	1100	Ball bearing	LH-SE 200K	BH-SE 200K	LH-SE 200K-FI

## SETH SERIES

Heavy duty wheels with Blicke Extrathane® polyurethane tread  
Welded steel wheel centre  
1540 to 2200 lbs



### WHEEL DESCRIPTION:

Made of Blicke Extrathane® polyurethane, firmly bonded, light brown colour, non-marking, 92° shore A, elastic, abrasion-resistant, high cut and tear propagation resistance, non-staining, floor-saving, low noise operation, low rolling resistance, very good chemical connection with the wheel centre.

### RIGS: LO/BO SERIES

**Heavy welded steel construction**, swivel bracket with double ball bearing in the swivel head, additionally reinforced by the integration of four specially shaped and hardened bearing seats, labyrinth swivel head sealing with grease nipple, welded very strong, bolted and secured central kingpin, bolted wheel axle, zinc-plated.

### EXTRATHANE® POLYURETHANE – PRECISION BALL BEARING

6"	8 1/16"	2"	5 1/2" x 4 3/8"	4 1/8" x 3 1/8"	lbs	bearing type	swivel	rigid	"stop-top" brake
6"	8 1/16"	2"	5 1/2" x 4 3/8"	4 1/8" x 3 1/8"	1540	Ball bearing	LO-SETH 160K	BO-SETH 160K	LO-SETH 160K-ST
8"	9 5/8"	2"	5 1/2" x 4 3/8"	4 1/8" x 3 1/8"	2200	Ball bearing	LO-SETH 200K	BO-SETH 200K	LO-SETH 200K-ST

## GSPO SERIES

Extra heavy duty wheels made of cast nylon  
1540 to 6600 lbs

### WHEEL DESCRIPTION:

Made of hard and tough, highly compressed cast nylon with very high load capacity, high abrasion resistance, low rolling resistance, smooth running performance on even floors, shock and impact-resistant, corrosion-resistant, high chemical resistance to alcohol, salts, greases and certain acids and substances in diluted chemical solutions. Ball bearing, natural beige colour.

### RIGS: LH/BH SERIES

**Pressed steel**, swivel bracket with heavy fork and top plate, very strong bolted and secured central kingpin, double ball bearing in the swivel head, additionally reinforced by the integration of four specially shaped and hardened bearing seats resulting in a very high resistance to shock and impact loads, bolted wheel axle, zinc-plated.

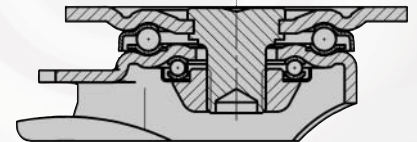

### CAST NYLON WHEELS – PRECISION BALL BEARING



					lbs	bearing type	swivel	rigid	"stop-fix" brake
3"	4 3/4"	1 1/2"	4" x 3 5/16"	3 1/8" x 2 1/8"	1540	Ball bearing	LH-GSPO 80K	BH-GSPO 80K	LH-GSPO 80K-ST*
4"	5 1/2"	1 1/2"	4" x 3 5/16"	3 1/8" x 2 1/8"	1540	Ball bearing	LH-GSPO 100K-I	BH-GSPO 100K	LH-GSPO 100K-I-FI
5"	6 11/16"	2 1/4"	5 1/2" x 4 3/8"	4 1/8" x 3 1/8"	1980	Ball bearing	LH-GSPO 125K	BH-GSPO 125K	LH-GSPO 125K-FI

\* "stop-top" brake

### RIGS: LS/BS SERIES

**Very rugged welded steel construction**, swivel bracket with axial grooved ball bearing DIN 711 and tapered roller bearing DIN 720 in the swivel head, dust and splash proof. Fitted grease nipple, welded very strong, bolted and secured central kingpin, bolted wheel axle.

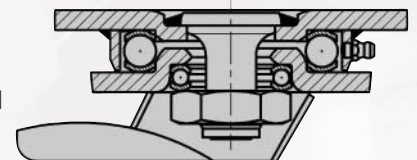

					lbs	bearing type	swivel	rigid	"stop-top" brake
4"	5 11/16"	2 1/4"	5 1/2" x 4 3/8"	2 15/16" x 4 1/8"	3300	Ball bearing	LS-GSPO 101K	BS-GSPO 101K	LS-GSPO 101K-ST
5"	6 11/16"	2 1/4"	5 1/2" x 4 3/8"	2 15/16" x 4 1/8"	3850	Ball bearing	LS-GSPO 125K	BS-GSPO 125K	LS-GSPO 125K-ST
6"	8 1/8"	2 1/4"	6 7/8" x 5 1/2"	5 1/2" x 4 1/8"	5500	Ball bearing	LS-GSPO 150K-35	BS-GSPO 150K-35	LS-GSPO 150K-35-ST
8"	10"	2 1/4"	6 7/8" x 5 1/2"	5 1/2" x 4 1/8"	6600	Ball bearing	LS-GSPO 200K-35	BS-GSPO 200K-35	LS-GSPO 200K-35-ST

## SPO SERIES

Heavy duty nylon wheels  
1650 to 4400 lbs

### WHEEL DESCRIPTION:

Made of high quality nylon, very rugged, natural white colour, high abrasion resistance, low rolling resistance, smooth running performance on even floors, shock and impact-resistant, corrosion-resistant, high chemical resistance to alcohol, salts, greases and certain acids and substances in diluted chemical solutions. Ball bearing, natural beige colour.



### INJECTION MOULDED NYLON – PRECISION BALL BEARING



					lbs	bearing type	swivel	rigid	"stop-top" brake
5"	6 11/16"	2"	5 1/2" x 4 3/8"	4 1/8" x 3 1/8"	1650	Ball bearing	LS-SPO 127K	BS-SPO 127K	LS-SPO 127K-ST
6"	8"	2"	5 1/2" x 4 3/8"	4 1/8" x 3 1/8"	1760	Ball bearing	LS-SPO 150K	BS-SPO 150K	LS-SPO 150K-ST
8"	9 5/8"	2"	6 1/2" x 4 3/8"	4 1/8" x 3 1/8"	3300	Ball bearing	LS-SPO 200K	BS-SPO 200K	LS-SPO 200K-ST
10"	12"	2 1/2"	7 1/2" x 4 3/8"	5 1/2" x 4 1/8"	4400	Ball bearing	LS-SPO 250K	BS-SPO 250K	LS-SPO 250K-ST

## VLE SERIES

Heavy duty wheels with super-elastic solid rubber tread  
Pressed steel rim  
570 to 2100 lbs



### WHEEL DESCRIPTION:

This 3 component tire consists of:

- **Rubber core:** Steel wire cores embedded in a tough and hard rubber compound to ensure a tight tread seat on the rim.
- **Cushion layer:** Ensures shock and vibration absorption, which protects the transport equipment and goods, low rolling resistance and minimum energy consumption.
- **Tread:** The thick abrasion-resistant tread ensures a long service life.

**RIMS:** Heavy flat-base design, pressed steel, bolted, zinc-plated.

### RIGS: LS/BS SERIES

**Very rugged welded steel construction**, swivel bracket with axial grooved ball bearing DIN 711 and tapered roller bearing DIN 720 in the swivel head, dust and splash proof. Fitted grease nipple, welded very strong, bolted and secured central kingpin, bolted wheel axle.

### SUPER ELASTIC SOLID RUBBER TIRES – PRECISION BALL BEARING



					lbs	bearing type	swivel	rigid	"stop-top" brake
10"	12"	3 3/8"	6 7/8" x 5 1/2"	5 1/2" x 4 1/8"	570	Ball bearing	LS-VLE 250K	BS-VLE 250K	LS-VLE 250K-ST
12"	14"	4"	8 7/8" x 6 1/4"	6 1/4" x 4 3/4"	1200	Ball bearing	LS-VLE 305K	BS-VLE 305K	***
16"	18 5/8"	4"	8 7/8" x 6 1/4"	6 1/4" x 4 3/4"	2100	Ball bearing	LS-VLE 405K	BS-VLE 405K	***

\*\*\* "Radstop" brake, please see options below

## OPTIONS AVAILABLE



non-marking tire	anti-static tire	with "Radstop" wheel brake	with directional lock 2 x 180°
-SN	-AS	-RA	-R2

To order caster with one of these options, please add suffix (-SN, -AS, -RA, -R2) to product number.

## VSTH SERIES

Light duty wheel  
220 lbs

### WHEEL DESCRIPTION:





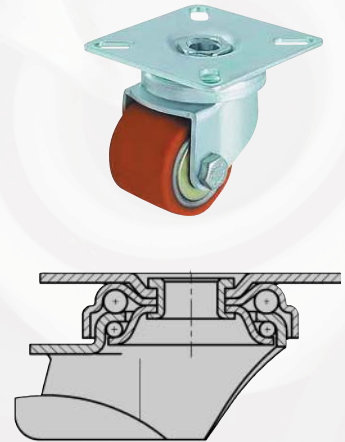

Made of Blicke Extrathane® polyurethane, firmly bonded, light brown colour, non-marking, 92° shore A, elastic, abrasion-resistant, high cut and tear propagation resistance, non-staining, floor saving, low noise operation, low rolling resistance, very good chemical connection with the wheel centre.

### RIGS: LPA SERIES

**Pressed steel**, swivel bracket with double ball bearing in the swivel head, bolted wheel axle, zinc-plated.



### EXTRATHANE® POLYURETHANE – PRECISION BALL BEARING

							
1 3/8"	2 1/16"	1"	2 3/8" x 2 3/8"	1 7/16 x 1 7/16	220 lbs	Ball bearing	swivel LPA-VSTH 35K

## VSTH SERIES

Light duty wheel  
220 lbs

### WHEEL DESCRIPTION:







Made of Blicke Extrathane® polyurethane, firmly bonded, light brown colour, non-marking, 92° shore A, elastic, abrasion-resistant, high cut and tear propagation resistance, non-staining, floor saving, low noise operation, low rolling resistance, very good chemical connection with the wheel centre.

### RIGS: LRA SERIES

**Pressed steel**, swivel bracket with double ball bearing in the swivel head, **bolt hole fitting**, bolted wheel axle, zinc-plated.



### EXTRATHANE® POLYURETHANE – PRECISION BALL BEARING

							
1 3/8"	2"	1"	raceway diameter 1 11/16"	bolt hole diameter 11 mm	220 lbs	Ball bearing	swivel LRA-VSTH 35K

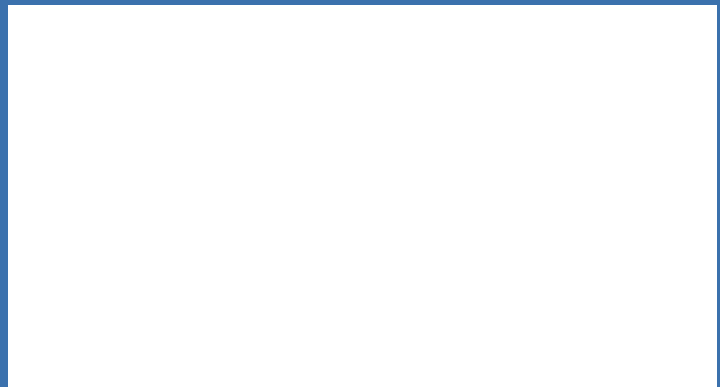

**[www.bleutec.com](http://www.bleutec.com)**

*For information on new products and promotions, visit our Web site and register to "THE LEADER.COM", our periodical newsletter.*